

JVC

Instruction Manual Soundbar

TH-W513B



Contents

Safety Warnings	4
Unpacking	6
Product Overview	7
Main Unit.....	7
Remote Control	8
Preparation	9
First-time Use of Remote Control	9
Battery Replacement for the Remote Control	9
Remote Control Operation Range.....	10
Soundbar Placement	10
Wall Mounting.....	11
Connections	12
Connecting to the TV	12
Connecting to an External Audio Device	13
Connecting to the Mains Supply	14
Basic Operating	14
Standby / ON	14
Setting Time in Standby mode.....	15
Automatic Power Off Function	15
Selecting Modes.....	15
Adjust the Speaker Level Settings and Effects	15
AUX / LINE IN / OPTICAL / COAXIAL Operation	16
Bluetooth® Operation	16
Maintenance	17
Hints and Tips	17
Product Fiche and Specifications	18
Others Information and Licences	19

Safety Warnings

- Read all the instructions carefully before using the unit and keep them for future reference.
- Retain the manual. If you pass the unit onto a third party make sure to include this manual.
- Check that the voltage marked on the rating label matches your mains voltage.

Damage

- Please inspect the unit for damage after unpacking.
- Do not continue to operate the unit if you are in any doubt about it working normally, or if it is damaged in any way - switch off, withdraw the mains plug and consult your dealer.

Location of Unit

- The unit must be placed on a flat stable surface and should not be subjected to vibrations.
- Do not place the unit on sloped or unstable surfaces as the unit may fall off or tip over.
- The mains socket must be located near the unit and should be easily accessible.
- This unit is designed for indoor, domestic use only.

Temperature

- Avoid extreme degrees of temperature, either hot or cold. Place the unit well away from heat sources such as radiators or gas / electric fires.
- Avoid exposure to direct sunlight and other sources of heat.
- Attention should be drawn to the use of apparatus in moderate climates.

Naked Flames

- Never place any type of candle or naked flame on the top of or near the unit.

Moisture

- To reduce the risk of fire, electric shock or product damage, do not expose this unit to rain, moisture, dripping or splashing. No objects filled with liquids, such as vases, should be placed on the unit. Do not operate the unit with wet hands, near water or other liquid.
- If you spill any liquid into the unit, it can cause serious damage. Switch it off at the mains immediately. Withdraw the mains plug and consult your dealer.

Ventilation

- To prevent the risk of electric shock or fire hazard due to overheating, ensure that curtains and other materials do not obstruct the ventilation vents.
- A minimum distance of 5 cm around the unit should be maintained to allow for sufficient ventilation.
- Do not install or place this unit in a bookcase, built-in cabinet or in another confined space. Ensure the unit is well ventilated.

Safety

- Always disconnect the unit from the mains supply before connecting / disconnecting other devices or moving the unit.
- Unplug the unit from the mains socket during a lightning storm.
- In the interests of safety and to avoid unnecessary energy consumption, never leave the unit switched on while unattended for long periods of time, e.g. overnight, while on holiday or while out of the house. Switch it off and disconnect the mains plug from the mains socket.

Mains Cable

- Make sure the unit or unit stand is not resting on top of the mains cable, as the weight of the unit may damage the mains cable and create a safety hazard.
- If the mains cable is damaged it must be replaced by the manufacturer, its service agent, or similarly qualified persons in order to avoid a hazard.



The mains plug is used as disconnect device, the disconnect device shall remain readily operable.

Mains Adapter

- The mains adapter will continue to draw electricity from the mains supply when plugged in the mains socket. In the interests of safety and to avoid unnecessary energy consumption, never leave the adapter plugged in the mains socket while unattended for long periods of time. Disconnect the adapter from the power supply.



Use only power supplies listed in the user instructions.

Interference

- Do not place the unit on or near appliances which may cause electromagnetic interference. If you do, it may adversely affect the operating performance of the unit, and cause a distorted picture or sound.

Batteries

- Batteries used in the remote control for this unit are easily swallowed by young children and this is dangerous.
- Keep loose batteries away from young children and make sure that the battery holder tray is secure in the remote control. Seek medical advice if you believe a cell has been swallowed.
- Please dispose of batteries correctly by following the guidance in this manual.
- Do not expose the battery to direct sunlight or sources of excessive heat.
- Do not ingest the battery, Chemical Burn Hazard.
- The remote control supplied with this product contains a coin/button cell battery. If the coin/button cell battery is swallowed, it can cause severe internal burns in just 2 hours and can lead to death.
- Keep new and used battery away from children.
- If the battery compartment does not close securely, stop using the product and keep it away from children.
- If you think batteries might have been swallowed or placed inside any part of the body, seek immediate medical attention.
- Attention should be drawn to the environmental aspects of battery disposal.

Supervision

- Children should be supervised to ensure that they do not play with the unit and the remote control.
- Never let anyone especially children push anything into the holes, slots or any other openings in the case - this could result in a fatal electric shock.



The lightning flash with arrowhead symbol, within an equilateral triangle, is intended to alert the user to the presence of uninsulated "dangerous voltage" within the unit's enclosure that may be of sufficient magnitude to constitute a risk of electric shock.



The exclamation point within an equilateral triangle is intended to alert the user to the presence of important operating and maintenance (servicing) instructions in the manual accompanying the unit.

Service

- To reduce the risk of electric shock, do not remove screws. The unit does not contain any user-serviceable parts. Please leave all maintenance work to qualified personnel.
- Do not open any fixed covers as this may expose dangerous voltages.

Maintenance

- Ensure to unplug the unit from the mains socket before cleaning.
- Do not use any type of abrasive pad or abrasive cleaning solutions as these may damage the unit's surface.
- Do not use liquids to clean the unit.



To prevent the spread of fire, keep candles or other open flames away from this product at all times.



This equipment is a Class II or double insulated electrical appliance. It has been designed in such a way that it does not require a safety connection to electrical earth.

~ **AC voltage:** This symbol indicates that the rated voltage marked with the symbol is AC voltage.

≡ **DC voltage:** This symbol indicates that the rated voltage marked with the symbol is DC voltage.

Thank you

for purchasing your new product. We recommend that you spend some time reading this instruction manual in order that you fully understand all the operational features it offers. You will also find some hints and tips to help you resolve any issues.

Read all the safety instructions carefully before use and keep this instruction manual for future reference.

Unpacking

Remove all items from the packaging. Retain the packaging. If you dispose of it please do so according to local regulations.

The following items are included:



Main Unit



Remote Control
(battery included)



Adapter for
Main Unit

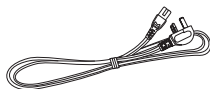

Mains Cable



3.5mm to 3.5mm
Stereo Audio Cable



Coaxial Cable



Wall Mount x 2

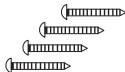

Screw x 4



Dowel x 4

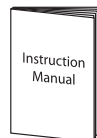

Instruction Manual



- To get the most from this product, you may need to buy an Optical cable.
- If items are missing, or damaged please contact Partmaster (UK only). Tel: 0344 800 3456 for assistance.
- If you require additional assistance:
For UK, please call our UK Call Centre on **0344 561 1234**.
For Ireland, please call our Ireland Call Center on **1 890 818 575**.

Product Overview

Main Unit

Front View

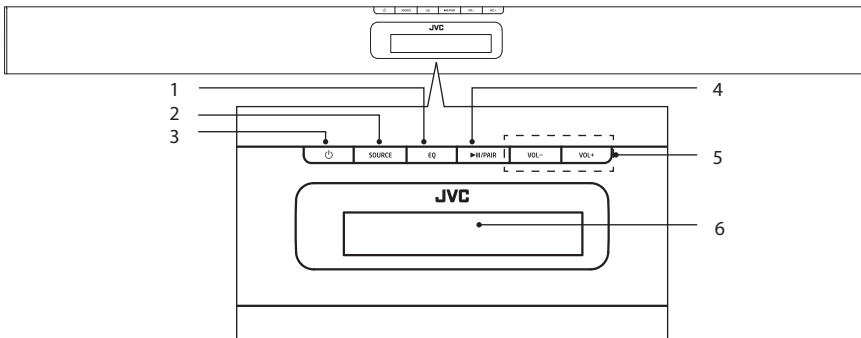

- EQ Button**
Select a preset sound effect.
- SOURCE Button**
Select the input source.
- Power Button**
Switch the unit between **ON** and **STANDBY** mode.
- PAIR Button**
 - Play / pause / resume playback in *Bluetooth*® mode.
 - Press and hold to activate the pairing function in *Bluetooth*® mode or to disconnect the existing paired *Bluetooth*® device in *Bluetooth*® mode.
- VOL+/VOL- Button**
Increase/decrease the volume level.
- Display**

Rear View and Sockets

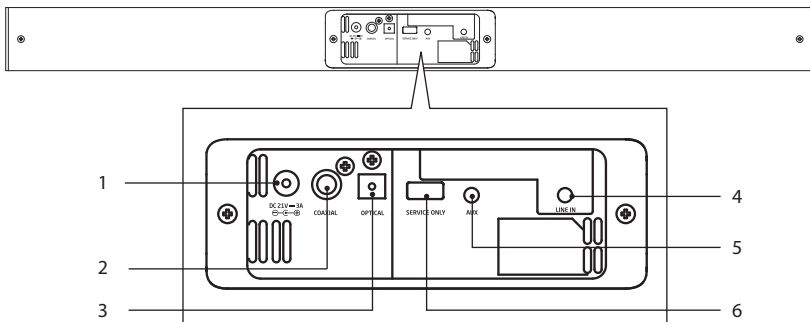

- DC 21V 3A** Socket
- COAXIAL** Socket
- OPTICAL** Socket
- SERVICE ONLY** Socket
- AUX** Socket
- LINE IN** Socket

Remote Control

1. **⏻** Button
Switch the unit between **ON** and **STANDBY** mode.
2. **SOURCE** Button
Select the Input source.
3. **VOL+ / VOL-** Button
Adjust the volume.
4. **⏮ / ⏭** Button
Skip backwards to the beginning of the track or to the previous track or skip forwards to the next track in *Bluetooth*[®] mode.
5. **▶II / PAIR** Button
 - Play / pause / resume playback in *Bluetooth*[®] mode.
 - Press and hold to activate the pairing function or disconnect the existing paired Bluetooth device in Bluetooth mode.
6. **MUTE** Button
Mute the unit or resume the sound.
7. **MOVIE** Button
Press to select **MOVIE** EQ effect.
8. **CUSTOM** Button
Press to select default EQ effect.
9. **MUSIC** Button
Press to select **MUSIC** EQ effect.
10. **BASS** Button
Press to activate bass setup in default EQ mode.
11. **TREBLE** Button
Press to activate treble setup in default EQ mode.

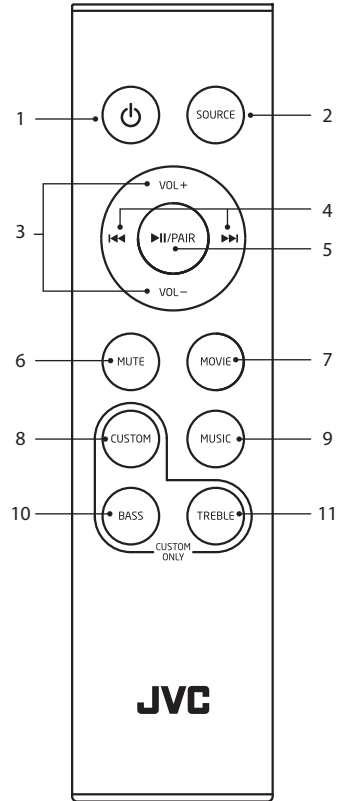

Preparation

First-time Use of Remote Control

The unit has a pre-installed lithium CR2025 battery.

Remove the protective tab to activate the remote control battery.

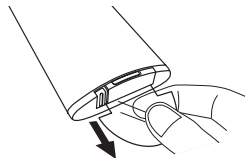

Battery Replacement for the Remote Control

1. Gently push the tab of the battery tray in and slide it free from the remote control.
2. Replace with a new CR2025 battery.
3. Slide the tray back into the remote control. There will be a click once it is back in place.

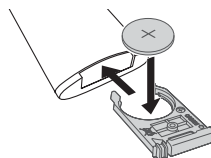
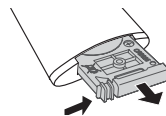

Handling the Battery

- Improper or incorrect use of batteries may cause corrosion or battery leakage, which could cause fire, personal injury or damage to property.
- Install the battery correctly in the battery compartment. Normally the battery's positive polarity (+) will face up.
- Only use the battery type indicated in this manual.
- Do not dispose of used batteries as domestic waste. Dispose of them in accordance with local regulations.
- Small button cell batteries such as the one used in the remote control are easily swallowed by young children and this is dangerous. Keep loose button cells away from young children and make sure that the battery is secure in the remote control. Seek medical advice if you believe a battery cell has been swallowed.

Handling the Remote Control

- Take care of your fingernails when you slide and pull the battery release tab.
- Do not drop the remote control.
- Do not allow anything to impact the remote control.
- Do not spill water or any liquid on the remote control.
- Do not place the remote control on a wet object.
- Do not place the remote control under direct sunlight or near sources of excessive heat.
- Remove the battery from the remote control when not in use for a long period of time, as corrosion or battery leakage may occur and result in physical injury, and / or property damage, and / or fire.
- When the battery is exhausted, the remote control will not function.

Remote Control Operation Range

- The remote control sensor on the front unit is sensitive to the remote control's commands up to a maximum of 6 metres away and within a maximum of a 60° arc.
- Please note that the operating distance may vary depending on the brightness of the room.

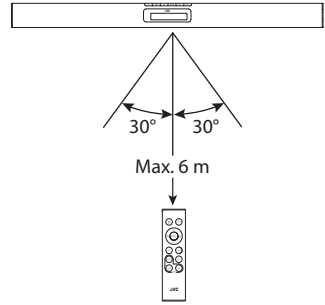

Soundbar Placement

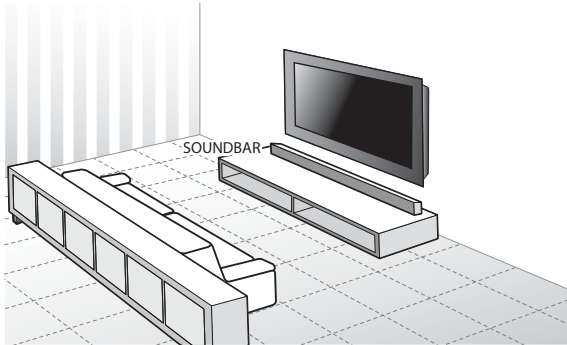

Soundbar

Soundbar carries most of the dialog as well as music and effects.

- If your TV is placed on a table, you can place the soundbar on the table directly in front of the TV stand, centered with the TV screen.
- If your TV is attached to a wall, you can mount the soundbar on the wall directly below the TV screen.

Wall Mounting



- Installation must be carried out by qualified personnel only. Incorrect assembly can result in severe personal injury and property damage (if you intend to install this product yourself, you must check for installations such as electrical wiring and plumbing that may be buried inside the wall). It is the installer's responsibility to verify that the wall will safely support the total load of the Soundbar and wall brackets.
- Additional tools (not included) are required for the installation.
- Do not overtighten screws.
- Keep this instruction manual for future reference.
- Use an electronic stud finder to check the wall type before drilling and mounting.

1. Drill 4 parallel holes (Ø 3-8 mm each according to wall type) in the wall. The distance between the holes should be 765 mm.

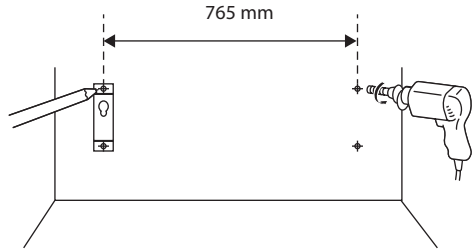

2. Firmly fix 1 dowel (included) into each hole in the wall if necessary.

Dowel



- ✓ Solid wall (i.e., Solid brick, Solid concrete, Solid wood, Solid wooden battens)
- ✗ Drywall, Plaster wall, Lath wall, etc.

3. Tighten the wall mount brackets on the wall with screws (included) and screwdriver (not included). Make sure that they are securely installed.

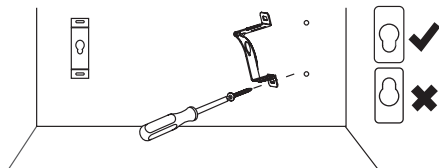

4. Loosen the screws at the back of the unit for 2 mm. Lift the unit onto the wall mount brackets and slot into place.

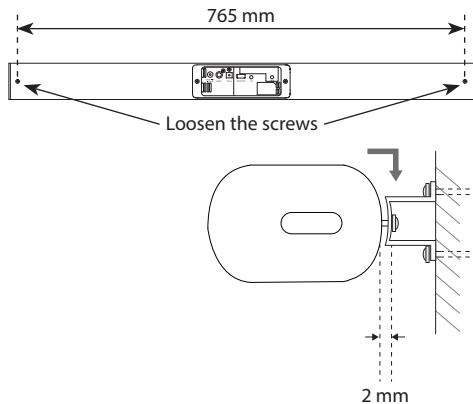

Connections



Ensure the unit is disconnected from the mains socket before connecting it to other devices.

Connecting to the TV

Method 1: Optical / Coaxial Connection

Use an optical cable (not included) / coaxial cable (included) to connect the soundbar's **OPTICAL / COAXIAL** socket to the **OPTICAL OUT / COAXIAL OUT** socket of the external device. The simplest option is to connect your soundbar directly to your TV. If you connect the soundbar to another external device (e.g. Blu-Ray player), you will hear the sound from that device through the soundbar.

Press **⏻** on the unit or remote control and then press **SOURCE** repeatedly to select **Optical** or **Coaxial** mode.

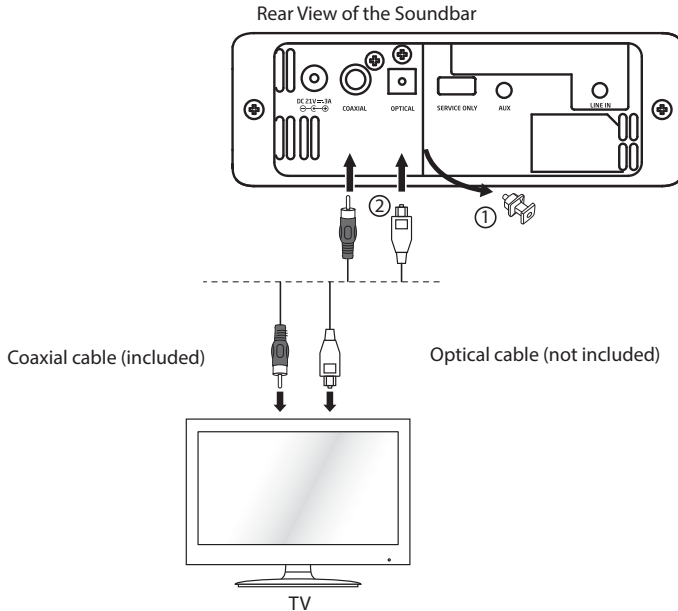

- If there is no sound output, the display will show "**PLEASE CHANGE YOUR SOURCE DEVICE TO PCM MODE UNDER AUDIO OUTPUT SETTING**". Ensure the audio setting of the input source (e.g. TV, games console, DVD player, etc) is set to **PCM** (Refer to the user manual of the input source device for its audio setting details) with optical / coaxial output.
- Before connecting the optical cable, remove the protective cap of the **OPTICAL** socket.

Method 2: AUX Connection

This is a basic connection for connecting your TV to your soundbar.

Connect a RCA to 3.5mm stereo audio cable (not included) to **AUX / LINE IN** socket on your soundbar and the **AUDIO OUT L / R** (white / red) sockets on your TV.

Press **⏻** on the unit or remote control and then press **SOURCE** repeatedly to select **AUX / LINE IN** mode.

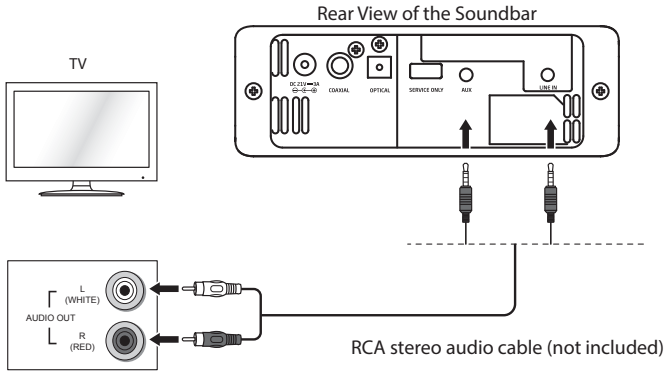

- Some TVs will have more than one **AUDIO L / R** sockets, ensure you use the sockets marked **OUT**. If you don't have an **AUDIO OUT** socket, this connection won't allow sound to your soundbar.
- Ensure to match the colours on the cable plugs to the colours on the output sockets.

Connecting to an External Audio Device

Use a 3.5mm to 3.5mm stereo audio cable (included) to connect the soundbar's **AUX / LINE IN** socket to the headphone socket of the external devices.

Press **⏻** on the unit or remote control and then press **SOURCE** repeatedly to select **AUX / LINE IN** mode.

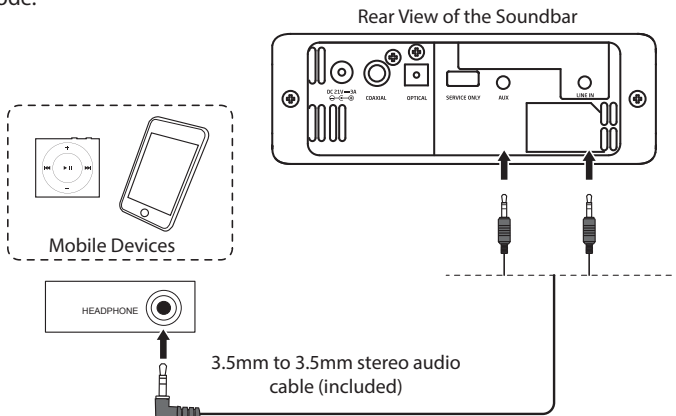

Connecting to the Mains Supply

The soundbar is designed to operate with the supplied mains adapter and mains cables.



- The mains adapter and mains cable are designed for this JVC soundbar only. DO NOT use the mains adapter and mains cable for other purposes. Connecting the unit to any other power source may damage the unit.
- Ensure all audio connections of the unit are connected before connecting to the mains power socket.
- Make sure the mains plug is firmly inserted into the mains socket.
- To switch the unit off completely, remove the mains plug from the mains socket.
- Please turn the unit off completely to save energy when not in use.

Soundbar

Unwind the mains adapter cable to its full length. Connect the mains cable to the mains adapter, and then connect the other end of the mains adapter to the **DC 21V** --- **3A** --- socket at the rear of the soundbar. Connect the mains plug to the mains socket.

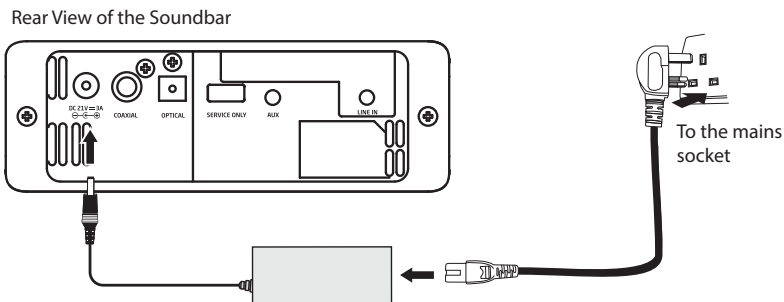

This instruction manual explains the basic instructions for operating this unit. Unless otherwise stated, all operations described are based on remote control use.

Basic Operating

Standby / ON

When you first connect the unit to the mains socket, the unit will be in **STANDBY** mode.

- Press the ⏻ Button on the unit or remote control to switch the main unit **ON**.
- Press the ⏻ Button on the unit or remote control again to switch the main unit back to **STANDBY** mode.
- Disconnect the mains plug from the mains socket if you want to switch the unit off completely.



- If a TV or an external device is connected to **AUX / LINE IN** socket, the main unit will switch on automatically when the TV or the external device is switched on. BUT in the following case, the unit will not switch on automatically in **AUX / LINE IN** mode:
 - after automatic power off function is activated. For details, please refer to the section "Automatic Power Off Function" below.

Setting Time in Standby mode

In **STANDBY** mode, the display will show "--:--", and then "**PRESS AND HOLD PAIR BUTTON TO SET TIME**". Press and hold **▶▶ / PAIR** on the unit or remote control to set the time.

1. Press **VOL+ / VOL-** Button on the unit or remote control to set the hours, then press **▶▶ / PAIR** on the unit or remote control to confirm.
2. Press **VOL+ / VOL-** Button on the unit or remote control to set the minutes, then **▶▶ / PAIR** on the unit or remote control to confirm.
3. The time is now set. When you switch the unit to **STANDBY** mode, the unit will show **STANDBY** and then the time clock.

Automatic Power Off Function

The unit automatically turns to **STANDBY** mode after 15 minutes if the TV or the external unit is disconnected or switched off in **OPTICAL** mode or the volume is too close to mute in **COAXIAL**, **AUX**, **LINE IN** and **BT** mode.



- To switch the unit off completely, remove the mains plug from the mains socket.
- Please turn the unit off completely to save energy when not in use.

Selecting Modes

Press **SOURCE** repeatedly on the main unit or remote control to switch between **BT**, **Optical**, **Coaxial**, **AUX** and **LINE IN** mode.

Adjust the Speaker Level Settings and Effects

Adjusting Volume

- Press **VOL+ / VOL-** on the unit or remote control to adjust the volume.
- If you wish to turn the sound off, press **MUTE**. The display will show "**MUTE**". Press **MUTE** again, or press **VOL+ / VOL-** to resume normal listening.

Select Equaliser (EQ) Effect

Press the **EQ** button on the unit or the **CUSTOM / MOVIE / MUSIC** button on the remote control to select the preset equaliser effects (**CUSTOM / MOVIE / MUSIC**).



- While the unit is in **COAXIAL**, **OPTICAL**, or **AUDIO IN** mode, it will automatically switch into **MOVIE EQ** effect.
- While the unit is in **Bluetooth** mode, it will automatically switch into **MUSIC EQ** effect.

Adjusting the Bass/Treble Level in CUSTOM EQ mode

1. Press **EQ** button on the unit repeatedly, or press **CUSTOM** button on the remote control to select default EQ mode.
2. Press **BASS / TREBLE** on the remote control. The display will show the current **BASS / TREB** level.
3. Press **VOL+ / VOL-** on the unit or remote control to adjust the bass/treble level (**-03** to **+03**).



The unit will exit from **BASS / TREBLE** setup after idle for about 5 seconds.

AUX / LINE IN / OPTICAL / COAXIAL Operation

There are **AUX / LINE IN / OPTICAL / COAXIAL** socket located at the rear of the unit. Audio sound signals from other sources can be connected to the unit through these sockets.

1. Before connecting to the mains socket, ensure all the connections are completed.
2. While in the **ON** mode, press **SOURCE** repeatedly to select **AUX / LINE IN / OPTICAL / COAXIAL** mode.
3. Operate your audio device directly for playback features.



While using **COAXIAL / OPTICAL** mode, ensure the audio setting of the input source (e.g. TV, games console, DVD player, etc.) is set to **PCM** (Refer to the user manual of the input source device for its audio setting details) with optical / coaxial output.

Bluetooth® Operation

The first time you connect your *Bluetooth*® device to this soundbar, you need to pair the unit with a *Bluetooth*® device to listen to music:

1. During **ON** mode, press **SOURCE** on the unit or remote control repeatedly to select **BT** mode. The screen will show **BT READY**.
2. Activate your *Bluetooth*® device and select the search mode. "**TH-W513B**" will appear on your *Bluetooth*® device list.
 - If you cannot find the soundbar, press and hold **▶II/ PAIR** on the unit or the remote control. The system has entered pairing mode. The unit will show **PAIR** and prompt "**Pairing**".
3. Select "**TH-W513B**" and enter "**0000**" for the password if necessary. The unit will voice "**Paired**" and the screen will show **PAIRED**.
4. To disconnect the *Bluetooth*® function, you can:
 - Switch to another function on the unit;
 - Disable the function from your *Bluetooth*® device. The *Bluetooth*® device will be disconnected from the soundbar after the "**Disconnected**" voice prompt;
 - Press and hold **▶II/ PAIR** on the unit or remote control. The *Bluetooth*® device will be disconnected from the soundbar after the "**Pairing**" voice prompt.

If your *Bluetooth*® device supports A2DP, play music via your device.

If your *Bluetooth*® device supports AVRCP, use the supplied remote control to control play.

- To pause / resume playback, press **▶II**.
- To skip to a track, press **◀◀/ ▶▶**.



- The operational range between the unit and the device is approximately 6 metres.
- Before connecting a *Bluetooth*® device to the unit, ensure you know the device's capabilities.
- Compatibility with all *Bluetooth*® devices is not guaranteed.
- Any obstacle between the device and the unit can reduce operational range.
- Keep this player away from other electronic devices that may cause interference.
- If no other *Bluetooth*® devices pair with this unit within 2 minutes, the unit will recover to its previous connection.
- The player will also be disconnected when your device is moved beyond the operational range.

Maintenance



Ensure the unit is fully unplugged from the mains socket before cleaning.

- To clean the units, wipe the case with a slightly moist, lint-free cloth.
- Do not use any cleaning fluids containing alcohol, ammonia or abrasives.
- Do not spray aerosol at or near the unit.

Hints and Tips

If a problem does occur, it may often be due to something very minor. The following table contains various tips. If you require additional assistance

- For UK, please call our UK Call Centre on **0344 561 1234**.
- For Ireland, please call our Ireland Call Center on **1 890 818 575**.

General

Problem	Solution
No power.	<ul style="list-style-type: none">• Ensure the mains plug is connected.• Make sure that you select the ON mode.
The remote control is not function.	<ul style="list-style-type: none">• Use the remote control near the unit.• Point the remote control at the remote sensor on the unit.• Replace the battery in the remote control with a new one.• Remove any obstacles between the remote control and the unit.
Loud hum or noise is heard.	<ul style="list-style-type: none">• The plugs and sockets are dirty. Wipe them with a cloth slightly moistened with alcohol.
The unit does not respond when pressing any buttons.	<ul style="list-style-type: none">• The unit may freeze up during use. Switch the unit off and then on again at the mains socket to reset the unit.
The unit will sometimes switch back to standby mode automatically.	The eco-friendly technology will switch this device to Standby mode automatically when the input volume is too low or muted for 15 minutes. Press the  button on the main unit or remote control to switch the main unit on again.

Bluetooth®

Problem	Solution
I cannot find " TH-W513B " on my Bluetooth® device.	<ul style="list-style-type: none">• Ensure the <i>Bluetooth®</i> function is activated on your <i>Bluetooth®</i> device.• Ensure you have paired your unit with the <i>Bluetooth®</i> device.

Product Fiche and Specifications

Brand		JVC
Model		TH-W513B
Power Adapter (Use only power adapter listed below)		
Power Adapter Manufacturer		Zhong Shan City Richsound Electronic Industrial Ltd.
Power Adapter Model		RAD2103
Input		AC 220 - 240 V ~ 50/60 Hz, 1.8A
Output		DC 21 V = 3.0 A ⊖ ⊕
Main Unit		
Power Supply		DC 21 V = 3.0 A ⊖ ⊕
USB Service Port		5 V = 500 mA (for service use only) Do NOT use for other purpose
Amplifier Output Power		50 W rms × 2
Bluetooth®	Bluetooth® Version	Bluetooth® 3.0
	Maximum transmitted power	7 dBm
	Frequency band	2402 MHz ~ 2480 MHz
Ecodesign Information		
Information on Power Consumption	Power Consumption of Another Condition (Sound bar was connected to AC mains via power adapter, with information display)	< 1.0 W
	Network Standby Power Consumption	< 2.0 W
Time interval for power management function switches the unit automatically into Another Condition (Sound bar was connected to AC mains via power adapter, with information display)		Switch to another condition within 15 minutes after intended use
Power consumption in network standby if all wireless network ports are activated		3.0 W
How to activate wireless network port:		
<ul style="list-style-type: none"> • Connect the unit with power • Switch to wireless mode (e.g. Bluetooth, etc) 		
How to deactivate wireless network port:		
<ul style="list-style-type: none"> • Press the ⊕ Standby button 		
Net Weight		2.2 kg
Dimension (W x H x D)		800 × 62 × 93 mm

Features and specifications are subject to change without prior notice.

Others Information and Licences



Team Knowhow

Help with all life's kit™

For general information about this appliance and handy hints and tips, please visit:

www.TeamKnowhow.com/discover

or call UK: **0344 561 1234**

Ireland: **1890 818 575**.

Partmaster
CO.UK

Visit Partmaster.co.uk today for the easiest way to buy electrical spares and accessories. With over 1 million spares and accessories available we can deliver direct to your door the very next day. Visit www.partmaster.co.uk or call 0344 800 3456 (UK customers only). Calls charged at National Rate.



The symbol on the product or its packaging indicates that this product must not be disposed of with your other household waste. Instead, it is your responsibility to dispose of your waste equipment by handing it over to a designated collection point for the recycling of waste electrical and electronic equipment. The separate collection and recycling of your waste equipment at the time of disposal will help conserve natural resources and ensure that it is recycled in a manner that protects human health and the environment.

For more information about where you can drop off your waste for recycling, please contact your local authority, or where you purchased your product.



Notes for Battery Disposal

The batteries used with this product contain chemicals that are harmful to the environment. To preserve our environment, dispose of used batteries according to your local laws or regulations. Do not dispose of batteries with normal household waste.

For more information, please contact the local authority or your retailer where you purchased the product.

The *Bluetooth*® word mark and logos are registered trademarks owned by Bluetooth SIG, Inc. and any use of such marks by DSG Retail Limited is under license. Other trademarks and trade names are those of their respective owners.

All trademarks are the property of their respective owners and all rights are acknowledged.

Dear Customer,

This apparatus is in conformance with the valid European directives compatibility and electrical safety.

European representative of the manufacturer is:

DSG Retail Ltd. (co. no. 504877)
1 Portal Way, London, W3 6RS, UK

For Help and Support Call

UK: 0344 561 1234

Ireland: 1890 818 575

The product is distributed and warranted exclusive by DSG Retail Ltd.
"JVC" is the trademark of JVC KENWOOD Corporation, used by DSG Retail Ltd. under license.

(IB-TH-W513B-180607V6)